

CA810 Motherboard Product Guide

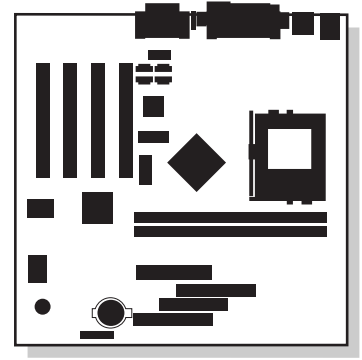

Order Number: 738718-001

Revision History

Revision	Revision History	Date
-001	Final version.	April 1999

If an FCC declaration of conformity marking is present on the board, the following statement applies:

FCC Declaration of Conformity

This device complies with Part 15 of the FCC Rules. Operation is subject to the following two conditions: (1) this device may not cause harmful interference, and (2) this device must accept any interference received, including interference that may cause undesired operation.

For questions related to the EMC performance of this product, contact:

Intel Corporation
5200 N.E. Elam Young Parkway
Hillsboro, OR 97124
1-800-628-8686

This equipment has been tested and found to comply with the limits for a Class B digital device, pursuant to Part 15 of the FCC Rules. These limits are designed to provide reasonable protection against harmful interference in a residential installation. This equipment generates, uses, and can radiate radio frequency energy and, if not installed and used in accordance with the instructions, may cause harmful interference to radio communications. However, there is no guarantee that interference will not occur in a particular installation. If this equipment does cause harmful interference to radio or television reception, which can be determined by turning the equipment off and on, the user is encouraged to try to correct the interference by one or more of the following measures:

- Reorient or relocate the receiving antenna.
- Increase the separation between the equipment and the receiver.
- Connect the equipment to an outlet on a circuit other than the one to which the receiver is connected.
- Consult the dealer or an experienced radio/TV technician for help.

Canadian Department of Communications Compliance Statement:

This digital apparatus does not exceed the Class B limits for radio noise emissions from digital apparatus set out in the Radio Interference Regulations of the Canadian Department of Communications.

Le présent appareil numérique n'émet pas de bruits radioélectriques dépassant les limites applicables aux appareils numériques de la classe B prescrites dans le Règlement sur le brouillage radioélectrique édicté par le ministère des Communications du Canada.

Disclaimer

Intel Corporation (Intel) makes no warranty of any kind with regard to this material, including, but not limited to, the implied warranties of merchantability and fitness for a particular purpose. Intel assumes no responsibility for any errors that may appear in this document. Intel makes no commitment to update nor to keep current the information contained in this document. No part of this document may be copied or reproduced in any form or by any means without prior written consent of Intel.

An Intel product, when used in accordance with its associated documentation, is "Year 2000 Capable" when, upon installation, it accurately stores, displays, processes, provides, and/or receives date data from, into, and between the twentieth and twenty-first centuries, including leap year calculations, provided that all other technology used in combination with said product properly exchanges date data with it.

† Third-party brands and trademarks are the property of their respective owners.

Copyright © 1999, Intel Corporation. All Rights Reserved

Contents

1 Motherboard Features

Feature Summary.....	7
Components.....	8
Microprocessor.....	9
Main Memory	9
Graphics Subsystem	10
Intel 82810 GMCH.....	10
GMCH DC-100 (Optional).....	11
Audio Subsystem	12
Creative Sound Blaster AudioPCI 64V Audio Controller	12
Crystal Semiconductor CS4297 Stereo Audio Codec	12
Audio Connectors	12
Audio Drivers and Utilities.....	13
Speaker.....	13
LAN Subsystem (Optional).....	13
Intel® 82559 LAN Controller	13
LAN Subsystem Software.....	14
RJ-45 LAN Connector LEDs.....	14
PCI Enhanced IDE Interface	14
Input/Output (I/O) Controller.....	15
Real-Time Clock.....	15
USB Support	16
BIOS	16
Intel® 82802AB Firmware Hub (FWH)	16
PCI Auto Configuration	16
IDE Auto Configuration	16
Security Passwords	17
Expansion Slots.....	17
Power Management Features	17
Wake on LAN Technology	18
Instantly Available Technology	19
Resume on Ring.....	20
Battery.....	20

2 Installing and Replacing Motherboard Components

Before You Begin	21
How to Install and Remove the Motherboard.....	22
How to Install a Motherboard Support Standoff	23
How to Remove the Processor.....	27
How to Install Memory	27
How to Remove Memory	30
How to Replace the Battery.....	30
How to Connect IDE Drives.....	32
How to Clear the Passwords	32

How to Set Jumpers	33
BIOS Setup Configuration Jumper Block	34
USB Port 0 Configuration Jumper Block (Optional)	34
3 Using the Setup Program	
BIOS Setup Program Modes	35
Function Keys.....	36
Accessing the Setup Program	36
Upgrading the BIOS	37
Obtaining the BIOS Upgrade File	37
Recording the Current BIOS Settings	37
Creating a Bootable Diskette	38
Creating the BIOS Upgrade Diskette	38
Upgrading the BIOS	39
Recovering the BIOS.....	39
Changing the BIOS Language.....	40
4 Technical Reference	
Motherboard Connectors.....	41
Back Panel Connectors	42
Midboard Connectors	43
Front Panel Connectors.....	44
Motherboard Resources.....	45
Memory Map	45
DMA Channels	45
I/O Map	46
Interrupts.....	48
A Error Messages	
BIOS Beep Codes	49
BIOS Error Messages	49
B Regulatory and Integration Information	
Regulatory Compliance	51
Product Certification Markings.....	52
Installation Precautions	52
Installation Instructions.....	53
Ensure Electromagnetic Compatibility (EMC)	53
Ensure Chassis and Accessory Module Certifications	53
Prevent Power Supply Overload.....	54
Place Battery Marking on the Computer	54
Use Only for Intended Applications.....	54
Figures	
1. Motherboard Components.....	8
2. Using the Wake on LAN Technology Connector.....	18
3. Location of Standby Power Indicator LED	19
4. Mounting Screw Holes.....	22

5. Motherboard Support Standoff in a Standard ATX Chassis	23
6. Raising the Socket Handle	24
7. Inserting the Processor into the Socket	24
8. Closing the Handle	25
9. Attaching the Heatsink to the Processor.....	25
10. Attaching the Fan Heatsink Clip	26
11. Connecting the Processor Fan Cable to the Processor Fan Connector.....	26
12. Installing a DIMM.....	29
13. Removing the Battery	31
14. Location of Configuration Jumper Block	33
15. Connector Groups	41
16. Back Panel Connectors and Indicators.....	42
17. Midboard Connectors	43
18. Front Panel Connectors.....	44

Tables

1. Processors Supported by the Motherboard.....	9
2. Intel 82810 GMCH Refresh Rates.....	11
3. RJ-45 LAN Connector LEDs	14
4. Jumper Settings for BIOS Setup Program Modes.....	34
5. USB Port 0 Configuration Jumper Settings	34
6. Setup Menu Screens	36
7. Setup Function Keys.....	36
8. System Memory Map.....	45
9. DMA Channels.....	45
10. I/O Map.....	46
11. Interrupts	48
12. Beep Codes	49
13. BIOS Error Messages.....	49
14. Safety Regulations.....	51
15. EMC Regulations.....	51

1 Motherboard Features

Feature Summary

Form Factor	MicroATX (9.6 inches by 9.6 inches)
Processor	Support for Intel® Celeron™ processor, in a 370-pin Plastic Pin Grid Array (PPGA) package, with 66-MHz host bus speed
Chipset	The Intel® 82810 chipset consisting of: <ul style="list-style-type: none">• Intel® 82810 Graphics/Memory Controller Hub (GMCH)• Intel® 82801AA I/O Controller Hub (ICH)• Intel® 82802AB 4 Mbit Firmware Hub (FWH)
Memory	<ul style="list-style-type: none">• Two 168-pin dual inline memory module (DIMM) sockets• Support for up to 512 MB of 100-MHz, non-ECC, unbuffered synchronous DRAM (SDRAM)<ul style="list-style-type: none">— 16 MB and 256 MB using 16 MB/64 Mbit technology— 512 MB using 128 Mbit technology• Support for serial presence detect (SPD) and non-SPD DIMMs
I/O Control	SMSC LPC47B272 super I/O controller
Peripheral Interfaces	<ul style="list-style-type: none">• Two serial ports (header only for second serial port)• Two Universal Serial Bus (USB) ports• One parallel port• PS/2[†] keyboard• PS/2 mouse
Audio	<ul style="list-style-type: none">• Creative Sound Blaster[†] AudioPCI 64V audio controller• Crystal Semiconductor CS4297 AC '97 stereo audio codec• Sony/Phillips Digital Interface Format (S/P-DIF) connector with Creative Sound Blaster AudioPCI 64V audio subsystems (optional)
Video	Intel 82810 Graphics/Memory Controller Hub (integrated in the chipset) Intel 82810 DC-100 Graphics/Memory Controller Hub (optional)
Expansion capabilities	Four PCI slots
Power Management	<ul style="list-style-type: none">• Supports Advanced Power Management (APM)• Supports Advanced Configuration and Power Management Interface (ACPI) including Suspend to RAM (STR)
BIOS	<ul style="list-style-type: none">• Intel/AMI BIOS• Intel 82802AB Firmware Hub (FWH) 4 Mbit flash memory
Other features	<ul style="list-style-type: none">• Speaker• SCSI HD Activity LED connector (optional)• Hardware monitor (optional)• Chassis intrusion detection (optional)• Enhanced diagnostics LEDs (optional)• Intel® 82559 PCI LAN controller with RJ-45 LAN connector (optional)

⇒ NOTE

For information about Intel® motherboards, including technical product specifications, BIOS upgrades, and device drivers, go to the Intel World Wide Web site at:

<http://support.intel.com/support/motherboards/desktop>

Components

Figure 1 shows the major components on the motherboard.

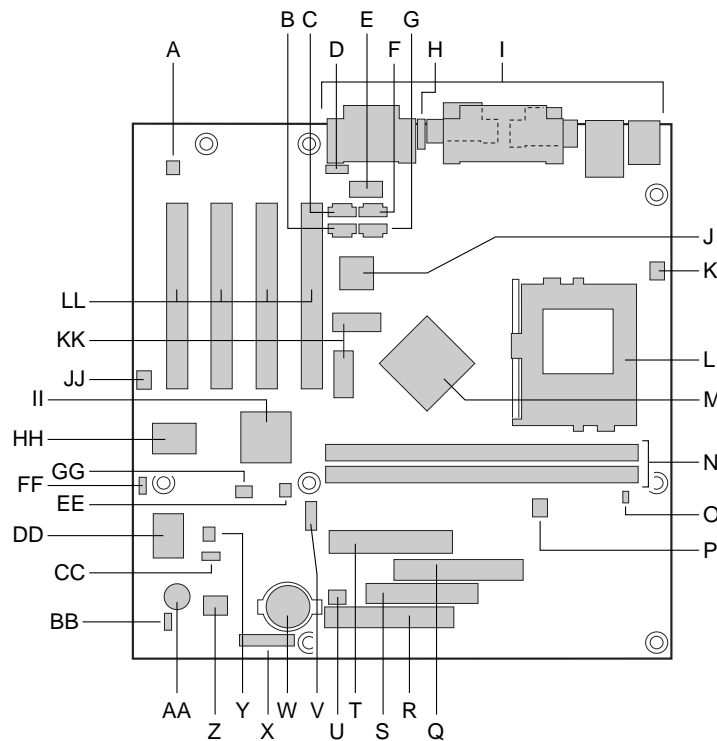

OM07766

A	Crystal Semiconductor CS4297 audio codec	T	Power supply connector
B	ATAPI-style CD-ROM connector	U	Fan 1 (chassis) connector
C	Video source line in connector (optional)	V	USB front panel connector (optional)
D	Legacy CD-ROM connector (optional)	W	Battery
E	Serial port B header	X	Front panel connector
F	Auxiliary line in connector (optional)	Y	SCSI HD Activity LED connector (optional)
G	Telephony connector (optional)	Z	Intel 82802AB Firmware Hub (FWH)
H	Enhanced diagnostics LEDs (optional)	AA	Speaker
I	Back panel connectors	BB	Alternative 1x3 front panel power LED connector
J	Intel 82559 LAN controller (optional)	CC	Wake on LAN† technology connector (optional)
K	Fan 3 (processor) connector	DD	SMSC LPC47B272 super I/O controller
L	370-pin PPGA processor socket	EE	Chassis intrusion connector (optional)
M	Intel 82810 Graphics/Memory Controller Hub (GMCH)	FF	Configuration jumper block
N	DIMM sockets	GG	USB front panel jumper block (optional)
O	Hardware monitor (optional)	HH	Creative Sound Blaster AudioPCI 64V audio controller
P	Fan 2 connector (optional)	II	Intel 82801AA I/O Controller Hub (ICH)
Q	Secondary IDE connector	JJ	Sony/Phillips Digital Interface Format connector (optional)
R	Primary IDE connector	KK	Video memory (optional)
S	Diskette drive connector	LL	PCI slots

Figure 1. Motherboard Components

⇒ **NOTE**

Components labeled optional do not come on all CA810 motherboards.

Microprocessor

The motherboard supports the 370-pin PPGA socketed Celeron processors listed in Table 1. All supported onboard memory can be cached.

Table 1. Processors Supported by the Motherboard

Processor Speed	Host Bus Frequency	Cache Size
466 MHz	66 MHz	128 KB
433 MHz	66 MHz	128 KB
400 MHz	66 MHz	128 KB
366 MHz	66 MHz	128 KB
333 MHz	66 MHz	128 KB
300A MHz	66 MHz	128 KB

For the latest information on processor support for the CA810 motherboard, refer to the Intel boxed motherboard web site at:

<http://support.intel.com/support/motherboards/desktop/>

For instructions on installing or upgrading the processor, see Chapter 2.

Main Memory

The motherboard has two sockets for installing DIMMs. Minimum memory size is 32 MB; maximum memory size is 512 MB. Due to the video requirements of the CA810 motherboard, minimum memory for the Windows NT[†] 4.0 operating system is 64 MB. For optimal video performance, it is recommended that 64 MB of memory be installed. See Chapter 2 for types of memory supported and installation instructions.

All supported onboard memory is cacheable.

⇒ **NOTE**

Some of the system memory is dedicated to video.

Graphics Subsystem

The graphics subsystem features the Intel 82810 Graphic/Memory Controller Hub (GMCH).

Visit Intel's World Wide Web site for information about graphics drivers:

<http://support.intel.com/support/motherboards/desktop/>

Intel 82810 GMCH

The Intel 82810 GMCH supports the following features:

- Integrated graphics controller
 - 3-D Hyper Pipelined architecture
 - Full 2-D hardware acceleration
 - Motion video acceleration
- 3-D graphics visual and texturing enhancements
- Display
 - Integrated 24-bit 230 MHz RAMDAC
 - DDC2B compliant
- Video
 - Hardware motion compensation for software MPEG2 decode
- Integrated graphics memory controller

Table 2 lists the refresh rates supported by the CA810 motherboard.

Table 2. Intel 82810 GMCH Refresh Rates

Resolution	Color	60 (Hz)	70 (Hz)	72 (Hz)	75 (Hz)	85 (Hz)
640x200	16		x			
640x350	16		x			
640x400	256	x	x		x	x
	64 K	x	x		x	x
	16 M		x			
640x480	16	x		x	x	x
	256	x	x	x	x	x
	32 K	x			x	x
	64 K	x	x	x	x	x
	16 M	x	x	x	x	x
800x600	256	x	x	x	x	x
	32 K	x			x	x
	64 K	x	x	x	x	x
	16 M	x	x	x	x	x
1024x768	256	x	x		x	x
	32 K	x			x	x
	64 K	x	x	x	x	x
	16 M	x	x	x	x	x
1056x800	16		x			
1280x1024	256	x	x	x	x	x
	32 K	x			x	
	64 K	x	x	x	x	x
	16 M	x	x	x	x	x

GMCH DC-100 (Optional)

In addition to all the features of the GMCH, the optional GMCH DC-100 supports 4 MB of display cache on the motherboard.

Audio Subsystem

The audio subsystem consists of these devices:

- Creative Sound Blaster AudioPCI 64V digital controller
- Crystal Semiconductor CS4297 AC '97 stereo audio codec
- Back panel and onboard audio connectors

Creative Sound Blaster AudioPCI 64V Audio Controller

The Creative Sound Blaster AudioPCI 64V audio controller features:

- Interfaces to the PCI bus as a Plug and Play device
- 100% DOS legacy compatible
- Access to main memory (through the PCI bus) for wavetable synthesis support – does not require a separate wavetable ROM device
- PC 98 and PC 99 compliant
- Optional Sony/Phillips digital interface format (S/P-DIF)

Crystal Semiconductor CS4297 Stereo Audio Codec

The Crystal Semiconductor CS4297 stereo audio codec features:

- High performance 18-bit stereo full-duplex audio codec with up to 48 kHz sampling rate
- Connects to the Sound Blaster AudioPCI 64V using a five-wire digital interface

Audio Connectors

The audio connectors include the following:

- CD-ROM (legacy-style 2 mm connectors)
- ATAPI-style connectors
 - CD-ROM audio
 - Auxiliary line in
 - Telephony (optional)
 - Video line in (optional)
- Back panel connectors
 - Line out
 - Line in
 - Mic in
 - MIDI/Game Port

⇒ NOTE

The line out connector, located on the back panel, is designed to power either headphones or amplified speakers only. Poor audio quality may occur if passive (non-amplified) speakers are connected to this output.

Audio Drivers and Utilities

Audio drivers and utilities are available from Intel's World Wide Web site:

<http://support.intel.com/support/motherboards/desktop>

Speaker

A 47 Ω inductive speaker is mounted on the motherboard. The speaker provides audible error code (beep code) information during the power-on self test (POST).

LAN Subsystem (Optional)

The Intel 82559 Fast Ethernet Wired for Management (WfM) PCI LAN subsystem provides both 10Base-T and 100Base-TX connectivity. Features include:

- 32-bit, 33 MHz direct bus mastering on the PCI bus
- Shared memory structure in the host memory that copies data directly to/from host memory
- 10Base-T and 100Base-TX capability using a single RJ-45 connector with connection and activity status LEDs
- IEEE 802.3 μ Auto-Negotiation for the fastest available connection
- Jumperless configuration; the LAN subsystem is completely software-configurable

Intel® 82559 LAN Controller

The Intel 82559 PCI LAN controller's features include:

- CSMA/CD Protocol Engine
- PCI bus interface
- DMA engine for movement of commands, status, and network data across the PCI bus
- Integrated physical layer interface, including:
- Jumperless configuration; the LAN subsystem is completely software-configurable
 - Complete functionality necessary for the 10Base-T and 100Base-TX network interfaces; when in 10 Mbit/sec mode, the interface drives the cable directly
 - A complete set of Media Independent Interface (MII) management registers for control and status reporting
 - 802.3 μ Auto-Negotiation for automatically establishing the best operating mode when connected to other 10Base-T or 100Base-TX devices, whether half- or full-duplex capable
- Integrated power management features, including:
 - Support for APM
 - Support for Wake on LAN technology
 - Support for ACPI D3 state

LAN Subsystem Software

The Intel 82559 Fast Ethernet WfM PCI LAN software and drivers are available from Intel's World Wide Web site.

RJ-45 LAN Connector LEDs

Two LEDs are built into the RJ-45 LAN connector. Table 3 describes the LED states when the board is powered up and the LAN subsystem is operating.

Table 3. RJ-45 LAN Connector LEDs

LED Color	LED State	Indicates
Green	Off	10 Mbit/sec speed is selected.
	On	100 Mbit/sec speed is selected.
Yellow	Off	LAN link is not established.
	On (steady state)	LAN link is established.
	On (brighter and pulsing)	The computer is communicating with another computer on the LAN.

PCI Enhanced IDE Interface

The PCI enhanced IDE interface handles the exchange of information between the processor and peripheral devices like hard disks, CD-ROM drives, and Iomega Zip[†] drives inside the computer. The interface supports:

- Up to four IDE devices (such as hard drives)
- ATAPI devices (such as CD-ROM drives)
- PIO Mode 3 and PIO Mode 4 devices
- Ultra ATA/33 and Ultra ATA/66
- Logical block addressing (LBA) of hard drives larger than 528 MB and extended cylinder head sector (ECHS) translation modes
- Support for laser servo (LS-120) drives

Input/Output (I/O) Controller

The SMSC LPC47B272 super I/O controller handles the exchange of information between the processor and external devices, such as a mouse, keyboard, or printer that are connected to the computer. The controller features the following:

- Low pin count (LPC) interface
- Two serial ports
- Infrared port (IrDA 1.1 compliant)
- One parallel port with Extended Capabilities Port (ECP) and Enhanced Parallel Port (EPP) support
- PS/2-style mouse and keyboard interfaces
- Interface for one 1.2 MB, 1.44 MB, or 2.88 MB diskette drive
- Intelligent power management, including a programmable wake up event interface
- Dual game port interface
- MPU-401 MIDI support
- Fan control:
 - Two pulse width modulation (PWM) fan speed control outputs
 - Two fan tachometer inputs

The BIOS Setup program provides configuration options for the I/O controller.

Real-Time Clock

The motherboard has a time-of-day clock and 100-year calendar that will rollover to 2000 at the turn of the century. A battery on the motherboard keeps the clock current when the computer is turned off.

⇒ NOTE

The recommended method of accessing the date in systems with Intel motherboards is indirectly from the Real-Time Clock (RTC) via the BIOS. The BIOS on Intel motherboards and baseboards contains a century checking and maintenance feature that checks the least two significant digits of the year stored in the RTC during each BIOS request (INT 1Ah) to read the date and, if less than 80 (i.e., 1980 is the first year supported by the PC), updates the century byte to 20. This feature enables operating systems and applications using the BIOS date/time services to reliably manipulate the year as a four-digit value.

For more information on proper date access in systems with Intel motherboards please see:

<http://support.intel.com/support/year2000/paper.htm>

USB Support

The motherboard has two USB ports. One of the USB ports can be routed to a front panel connector. You can connect two USB peripheral devices directly to the computer without an external hub. To attach more than two devices, connect an external hub to either of the built-in ports. The motherboard supports the standard universal host controller interface (UHCI) and takes advantage of standard software drivers written to be compatible with UHCI.

⇒ NOTE

Computer systems that have an unshielded cable attached to a USB port might not meet FCC Class B requirements, even if no device or a low-speed USB device is attached to the cable. Use a shielded cable that meets the requirements for a high-speed USB device.

BIOS

The BIOS provides the power-on self-test (POST), the BIOS Setup program, the PCI and IDE auto-configuration utilities, and the video BIOS.

The BIOS can be upgraded by following the instructions in Section 3.

Intel® 82802AB Firmware Hub (FWH)

The BIOS is stored in the Intel 82802AB Firmware Hub. The firmware hub contains a nonvolatile memory core based on Intel® flash technology. In addition to storing the system BIOS, the firmware hub incorporates logic features such as a hardware random number generator (RNG). These logic features enable protection for storing and updating platform information relating to security and manageability.

PCI Auto Configuration

If you install a PCI add-in board in your computer, the PCI auto-configuration utility in the BIOS automatically detects and configures the resources (IRQs, DMA channels, and I/O space) for that add-in board. You do not need to run the BIOS Setup program after you install a PCI add-in board.

IDE Auto Configuration

If you install an IDE device (such as, a hard drive) in your computer, the IDE auto-configuration utility in the BIOS automatically detects and configures the device for your computer. You do not need to run the BIOS Setup program after installing an IDE device.

Security Passwords

The BIOS includes security features that restrict whether the BIOS Setup program can be accessed and who can boot the computer. A supervisor password and a user password can be set for Setup and for booting the computer, with the following restrictions:

- The supervisor password gives unrestricted access to view and change all Setup options. This is supervisor mode.
- If only the supervisor password is set, pressing <Enter> at the password prompt of the Setup program gives the user restricted access to Setup.
- If both the supervisor and user passwords are set, you must enter either the supervisor password or the user password to access Setup.
- Setting a user password restricts who can boot the computer. The password prompt is displayed before the computer is booted. If only the supervisor password is set, the computer boots without asking for a password. If both passwords are set, you can enter either password to boot the computer.

Expansion Slots

The motherboard has four PCI expansion slots.

Power Management Features

Power management is implemented at several levels, including:

- Software support:
 - Advanced Power Management (APM)
 - Advanced Configuration and Power Interface (ACPI)
- Hardware support:
 - Wake on LAN technology
 - Instantly Available technology
 - Resume on Ring

If the board is used with an ACPI-aware operating system, the BIOS can provide ACPI support. Otherwise, it defaults to APM support.

Wake on LAN Technology

The optional Wake on LAN technology connector can be used with PCI bus network adapters that have a remote wake up connector, as shown in Figure 2. Network adapters that are PCI 2.2 compliant assert the wakeup signal through the PCI bus signal PME# (pin A19 on the PCI bus connectors). The optional onboard LAN subsystem also supports remote wakeup using the PME# signal.

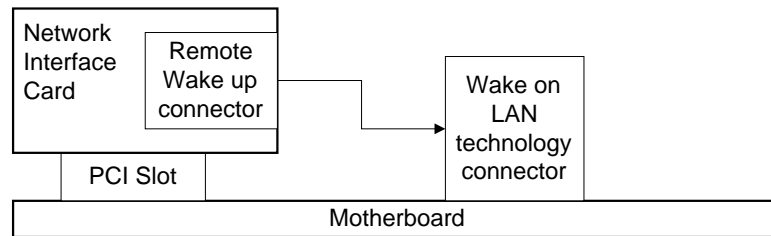

Figure 2. Using the Wake on LAN Technology Connector



CAUTION

For Wake on LAN technology, the 5-V standby line for the power supply must be capable of delivering +5 V \pm 5% at 720 mA. Failure to provide adequate standby current when implementing Wake on LAN technology can damage the power supply.

Instantly Available Technology

Instantly Available technology enables the board to enter the ACPI S3 (Suspend-to-RAM) sleep state. While in the S3 sleep state, the computer will appear to be off. When signaled by a wake up device or event, the system quickly returns to its last known wake state.

The optional standby power indicator (located between the DIMM sockets and power connector) provides an indication that power is still present to the DIMMs and PCI bus connectors, even when the computer appears to be off. Figure 3 shows the location of the standby power LED.

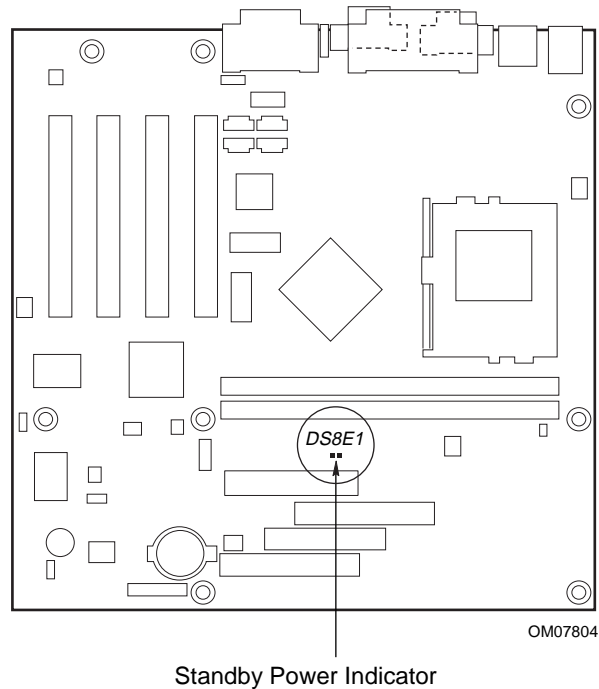

Figure 3. Location of Standby Power Indicator LED



CAUTION

For Instantly Available technology, the 5-V standby line for the power supply must be capable of delivering $+5\text{ V} \pm 5\%$ at 720 mA. Failure to provide adequate standby current when using this feature can damage the power supply.

Resume on Ring

The operation of Resume on Ring can be summarized as follows:

- Resumes operation from either the APM sleep mode or the ACPI S1 state
- Requires only one call to access the computer
- Detects incoming call similarly for external and internal modems; does not use the Wake on Ring connector
- Requires modem interrupt be unmasked for correct operation

Battery

A battery on the motherboard keeps the clock and the values in CMOS RAM current when your computer is turned off. See Chapter 2 for instructions on how to replace the battery.

2 Installing and Replacing Motherboard Components

This chapter tells you how to:

- Install and remove the motherboard
- Install and remove the processor
- Install and remove memory
- Replace the battery
- Connect IDE drives
- Clear passwords
- Set jumpers

Before You Begin



CAUTION

Before you install this motherboard in a chassis, see Appendix B for regulatory requirements and precautions.

- Always follow the steps in each procedure in the correct order.
- Set up a log to record information about your computer, such as model, serial numbers, installed options, and configuration information.
- Use an antistatic wrist strap and a conductive foam pad when working on the motherboard.



WARNINGS

The procedures in this chapter assume familiarity with the general terminology associated with personal computers and with the safety practices and regulatory compliance required for using and modifying electronic equipment.

Disconnect the computer from its power source and from any telecommunications links, networks, or modems before performing any of the procedures described in this chapter.

Failure to disconnect power, telecommunications links, networks, or modems before you open the computer or perform any procedures can result in personal injury or equipment damage.

Some circuitry on the motherboard can continue to operate even though the front panel power button is off.



CAUTION

Electrostatic discharge (ESD) can damage components. Perform the procedures described in this chapter only at an ESD workstation. If such a station is not available, you can provide some ESD protection by wearing an antistatic wrist strap and attaching it to a metal part of the computer chassis.

How to Install and Remove the Motherboard

Refer to your chassis manual for instructions on installing and removing the motherboard. On a microATX chassis, the motherboard is secured to the chassis by eight screws. Figure 4 shows the locations of the mounting screw holes. On a standard ATX chassis, the motherboard is secured to the chassis by seven screws and the provided standoff (see Figure 5).

⇒ NOTES

You will need a Phillips (#2 bit) screwdriver.

Refer to Appendix B for regulatory requirements and installation instructions and precautions.



WARNING

This procedure should be done only by qualified technical personnel. Disconnect the computer from its power source before doing the procedures described here. Failure to disconnect the power before you open the computer can result in personal injury or equipment damage.

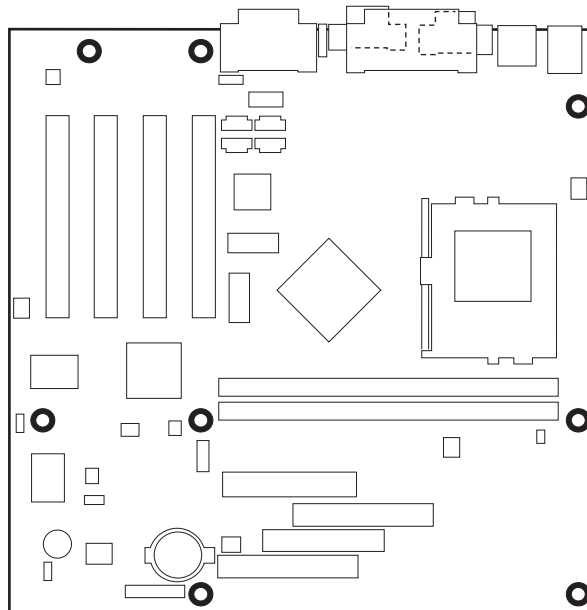

OM07790

Figure 4. Mounting Screw Holes

How to Install a Motherboard Support Standoff

The CA810 motherboard fits in a microATX chassis, but it can also be installed in a standard ATX chassis. When it is installed in a standard ATX chassis, one of the motherboard support positions might not have a corresponding standoff in the chassis. The following steps describe how to install an additional standoff in a standard ATX chassis and how to secure the motherboard to this added standoff. The Figure 5 shows the standoff (B), its associated adhesive pad (C), and a standoff retention pin (A).

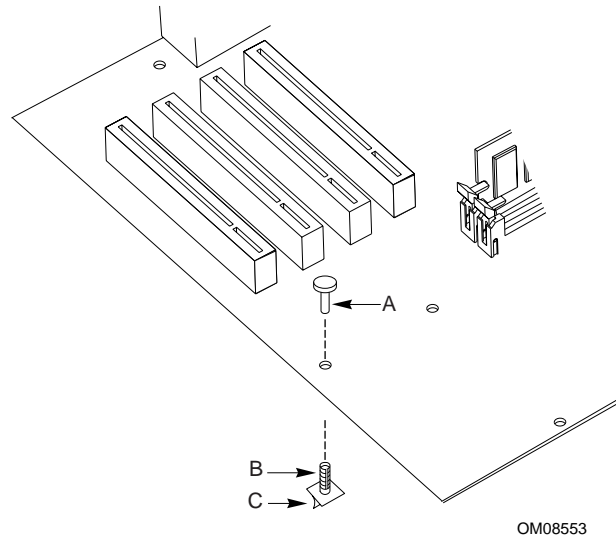

Figure 5. Motherboard Support Standoff in a Standard ATX Chassis

Do the following steps to install the added standoff for the motherboard:

1. Trial fit the added standoff (B) in the motherboard (in the position indicated in Figure 5), then position the motherboard in the ATX chassis on the existing standoffs, noting the required mounting location for the new standoff in the chassis.
2. Remove the motherboard, clean the mounting location, then remove the protective paper covering the adhesive (C) at the base of the added standoff (B).
3. Remount the motherboard in the chassis and press down on the added standoff (B) until the adhesive secures it to the chassis.
4. When final fitting the motherboard into the chassis, position the motherboard at the same height on the added standoff (B) as the other standoffs. Press the standoff retention pin (A) into the added standoff to lock the motherboard at that height.

How to Install the Processor

To install a processor, follow these instructions:

1. Observe the precautions in “Before You Begin” (see page 21).
2. Locate the processor socket and raise the socket handle completely (see Figure 6).

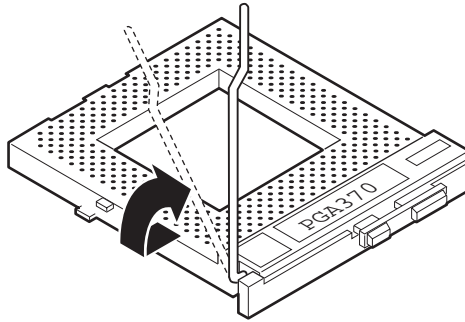

Figure 6. Raising the Socket Handle

3. Aligning the pins of the processor with the socket, insert the processor into the socket (see Figure 7).

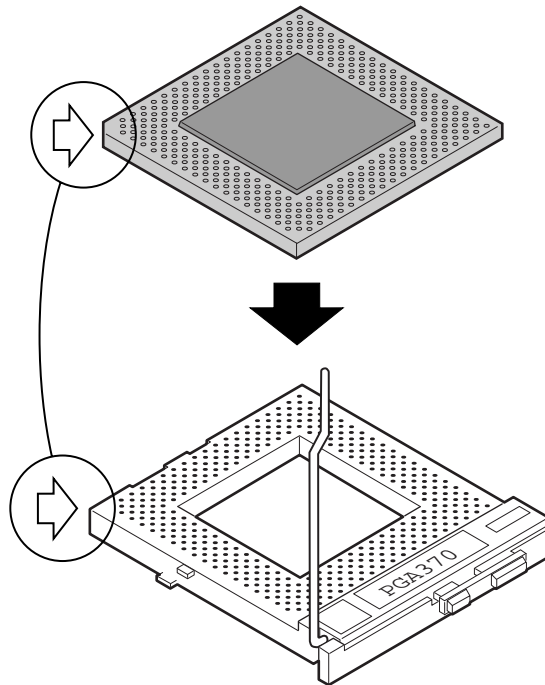
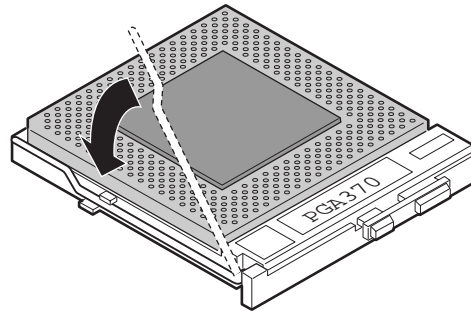

Figure 7. Inserting the Processor into the Socket

4. Close the handle completely (see Figure 8).



OM07803

Figure 8. Closing the Handle

5. Place the fan heatsink on top of the processor (see Figure 9).

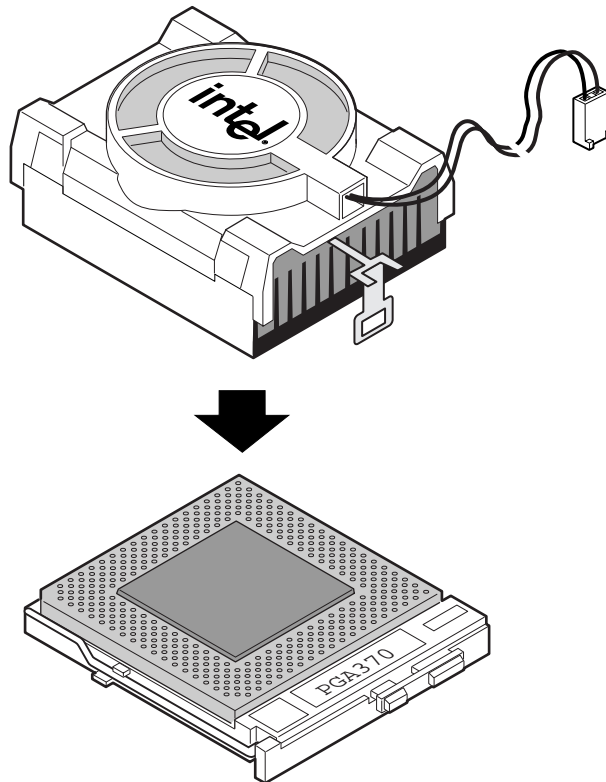

OM07800

Figure 9. Attaching the Heatsink to the Processor

6. Attach the fan heatsink clips to the processor socket (see Figure 10).

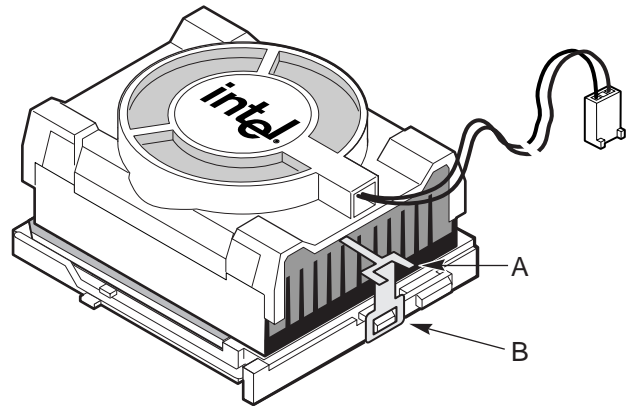

OM07798

- A Fan Heatsink Clip
- B Processor Socket

Figure 10. Attaching the Fan Heatsink Clip

7. Connect the processor fan cable to the processor fan connector (see Figure 11).

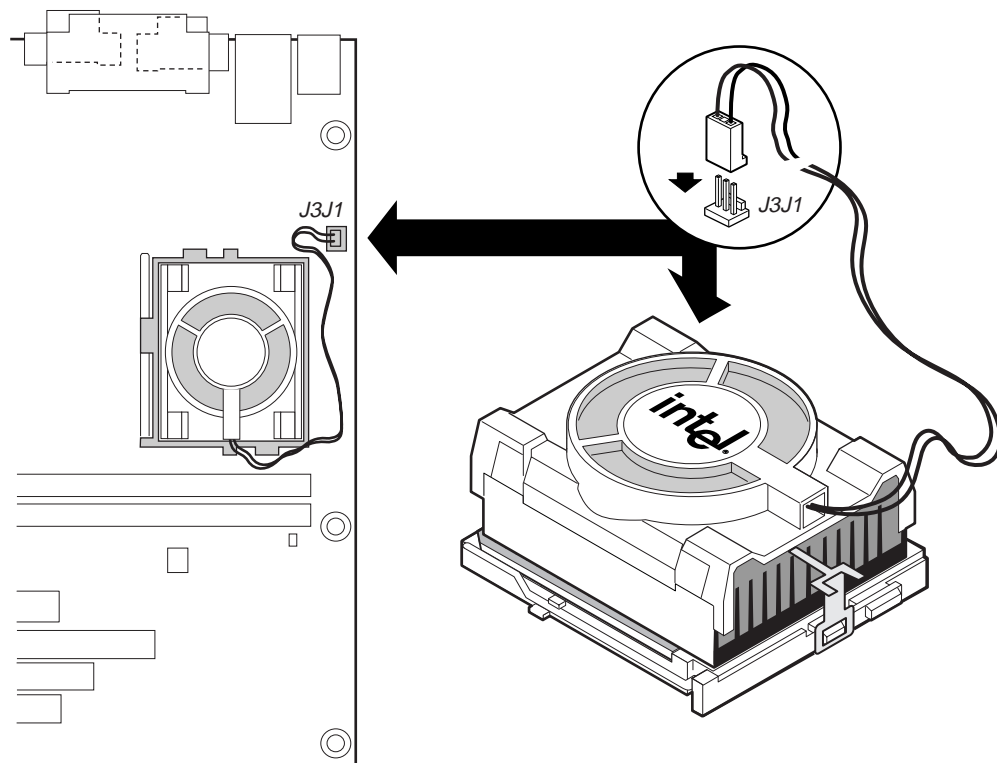

OM07799

Figure 11. Connecting the Processor Fan Cable to the Processor Fan Connector

How to Remove the Processor

To remove the processor, follow these instructions:

1. Observe the precautions in “Before You Begin” (see page 21).
2. Disconnect the processor fan cable.
3. Detach the fan heatsink clips.
4. Raise the socket handle completely.
5. Remove the processor.

How to Install Memory

You can install from 32 MB to 512 MB of memory in the DIMM sockets. The board has two DIMM sockets arranged as banks 0 and 1. As shown in Figure 11 on page 26, the DIMM socket closest to the processor is for bank 0. The motherboard supports the following memory features:

⇒ NOTE

On the CA810 motherboard, the minimum memory required is 64 MB for the Windows NT 4.0 operating system.

For optimal video performance, it is recommended that 64 MB of memory be installed.

- 168-pin 3.3 V DIMMs with gold-plated contacts
- 100 MHz 4-clock unbuffered SDRAM DIMMs
- Non-ECC (64-bit) memory
- A minimum of 32 MB (required); a maximum of 512 MB. For optimal video performance, use at least 64 MB of system memory.
- Module sizes: 16 MB, 32 MB, 64 MB, 128 MB, 256 MB, and 512 MB
- DIMMs with Serial Presence Detect (SPD) or non-SPD data structure



CAUTION

*Because the main system memory is also used as video memory, the CA810 motherboards require 100MHz SDRAM DIMMs even though the processor front side bus is 66 MHz. It is **highly** recommended that SPD DIMMs be used, since this allows the chipset to accurately configure memory settings for optimum performance. If non-SPD memory is installed, the BIOS will attempt to correctly configure the memory settings, but performance and reliability may be impacted.*

The motherboard supports single- or double-sided DIMMs in the following sizes:

DIMM Size	Non-ECC Configuration
16 MB	2 Mbit x 64
32 MB	4 Mbit x 64
64 MB	8 Mbit x 64
128 MB	16 Mbit x 64
256 MB	32 Mbit x 64

When adding memory, be aware that:

- You can install DIMMs in either of the two banks. That is, if only one DIMM is being installed, it can be placed in either DIMM socket.
- You can use different sizes of DIMMs in different banks.
- The BIOS detects the size and type of installed memory.

Figure 12 shows the location of the DIMM sockets.

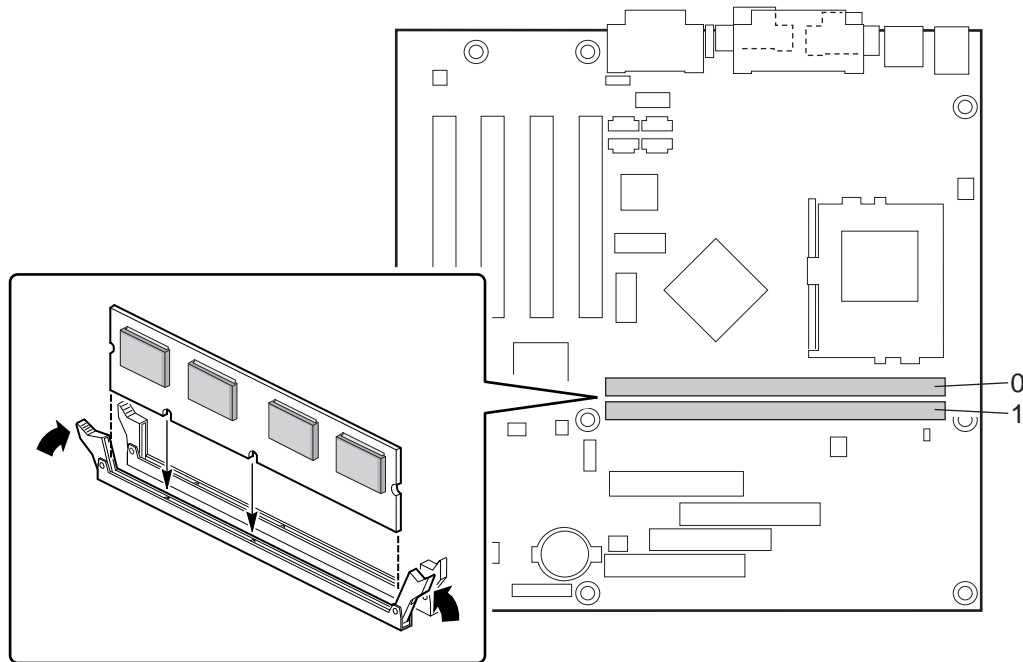

OM07791

Figure 12. Installing a DIMM

To install DIMMs, follow these steps:

1. Observe the precautions in “Before You Begin” (see page 21).
2. Turn off all peripheral devices connected to the computer. Turn off the computer. Unplug the computer.
3. Remove the computer cover and locate the empty DIMM sockets.
4. Holding the DIMM by the edges, remove it from its antistatic package.
5. Make sure the clips at either end of the socket are pushed away from the socket.
6. Position the DIMM above the socket. Align the two small notches in the bottom edge of the DIMM with the keys in the socket.
7. Insert the bottom edge of the DIMM into the socket (as shown in Figure 12).
8. When the DIMM is seated, push down on the top edge of the DIMM until the retaining clips snap into place. Make sure the clips are firmly in place.
9. Replace the computer cover.

How to Remove Memory

To remove a DIMM, follow these steps:

1. Observe the precautions in "Before You Begin" (see page 21).
2. Turn off all peripheral devices connected to the computer. Turn off the computer. Unplug the computer.
3. Remove the computer cover.
4. Gently spread the retaining clips at each end of the socket. The DIMM pops out of the socket.
5. Hold the DIMM by the edges, lift it away from the socket, and store it in an antistatic package.
6. Reinstall and reconnect any parts you removed or disconnected to reach the DIMM sockets.

How to Replace the Battery

When your computer is turned off, a lithium battery maintains the current time-of-day clock and the values in CMOS RAM current. Figure 13 on page 31 shows the location of the battery.

The battery should last about seven years. When the battery begins to die, it loses voltage; when the voltage drops below a certain level, the BIOS Setup program settings stored in CMOS RAM (for example, the date and time) might not be accurate. Replace the battery with an equivalent one.



WARNING

Danger of explosion if the battery is incorrectly replaced. Replace only with the same or equivalent type recommended by the equipment manufacturer. Discard used batteries according to manufacturer's instructions.



ATTENTION

Il y a danger d'explosion s'il y a remplacement incorrect de la batterie. Remplacer uniquement avec une batterie du même type ou d'un type recommandé par le constructeur. Mettre au rebut les batteries usagées conformément aux instructions du fabricant.



ADVARSEL!

Lithiumbatteri - Eksplosionsfare ved fejlagtig håndtering. Udskiftning må kun ske med batteri af samme fabrikat og type. Levér det brugte batteri tilbage til leverandøren.



ADVARSEL

Lithiumbatteri - Eksplosjonsfare. Ved utskifting benyttes kun batteri som anbefalt av apparatfabrikanten. Brukt batteri returneres apparatleverandøren.



VARNING

Explosionsfara vid felaktigt batteribyte. Använd samma batterityp eller en ekvivalent typ som rekommenderas av apparattillverkaren. Kassera använt batteri enligt fabrikantens instruktion.

**VAROITUS**

Paristo voi räjähtää, jos se on virheellisesti asennettu. Vaihda paristo ainoastaan laitevalmistajan suosittelemaan tyyppiin. Hävitä käytetty paristo valmistajan ohjeiden mukaisesti.

To replace the battery, follow these steps:

1. Observe the precautions in “Before You Begin” (see page 21).
2. Turn off all peripheral devices connected to the computer. Turn off the computer.
3. Remove the computer cover.
4. Locate the battery on the motherboard (see Figure 13).
5. With a medium flat-bladed screwdriver, gently pry the battery free from its socket. Note the orientation of the “+” and “-” on the battery.
6. Install the new battery in the socket, orienting the “+” and “-” correctly.
7. Replace the computer cover.

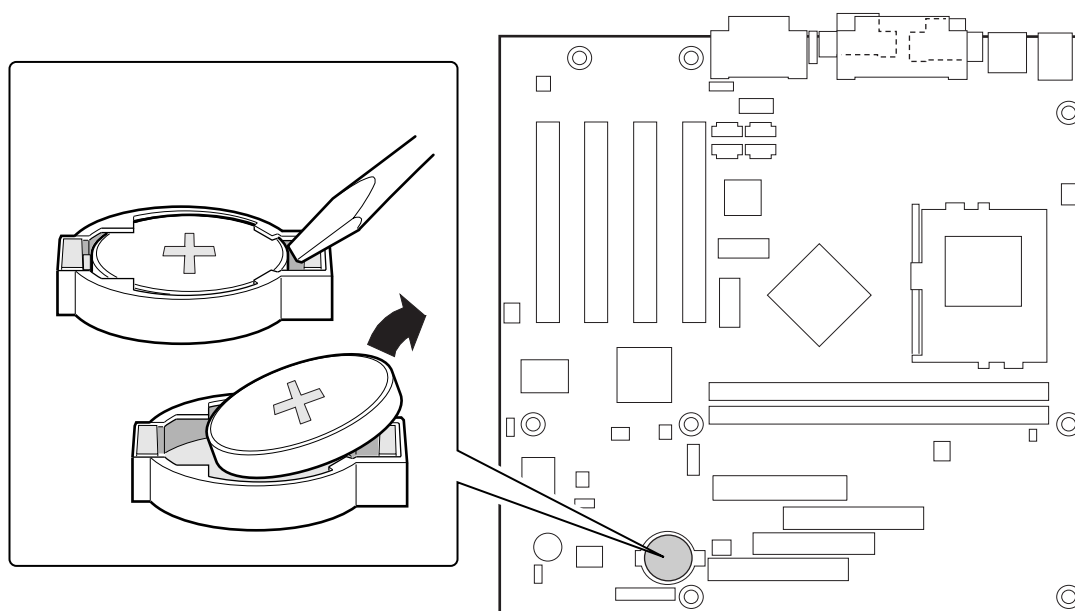

OM07792

Figure 13. Removing the Battery

**NOTE**

If your local ordinances permit, you may dispose of individual batteries as normal trash. Do not expose batteries to excessive heat or fire. Keep all batteries away from children.

How to Connect IDE Drives

The Intel boxed motherboard package includes an IDE cable. It is capable of connecting two drives to the motherboard.

The cable supports the Ultra ATA/66 interface and is backward compatible with drives using slower IDE transfer protocols. If an Ultra ATA/66 drive and a drive using any other IDE transfer protocol are attached to the same cable, the maximum transfer rate for either drive is 33 MB/second.

When building a system with both Ultra ATA/66 drives and slower drives, attach the Ultra ATA/66 drives to one channel with the Ultra ATA/66 cable. Attach the slower drives to the other channel with another cable.

How to Clear the Passwords

This procedure assumes that the motherboard is installed in the computer and the configuration jumper block is set to normal mode.

1. Observe the precautions in “Before You Begin” (see page 21).
2. Turn off all peripheral devices connected to the computer. Turn off the computer. Unplug the computer.
3. Remove the computer cover.
4. Find the configuration jumper block (see Figure 14).
5. Place the jumper on pins 2-3 as shown below.



6. Replace the cover, plug in the computer, turn on the computer, and allow it to boot.
7. The computer starts the Setup program. Setup displays the Maintenance menu.
8. Use the arrow keys to select Clear Passwords. Press <Enter> and Setup displays a pop-up screen requesting that you confirm clearing the password. Select Yes and press <Enter>. Setup displays the Maintenance Menu again.
9. Press <F10> to save the current values and exit Setup.
10. Turn off the computer. Unplug the computer.
11. Remove the computer cover.
12. To restore normal operation, place the jumper on pins 1-2 as shown below.



13. Replace the cover, plug in the computer, and turn on the computer.

How to Set Jumpers

CAUTION

Always turn off the power and unplug the power cord from the computer before changing the jumper. Moving the jumper with the power on may result in unreliable computer operation.

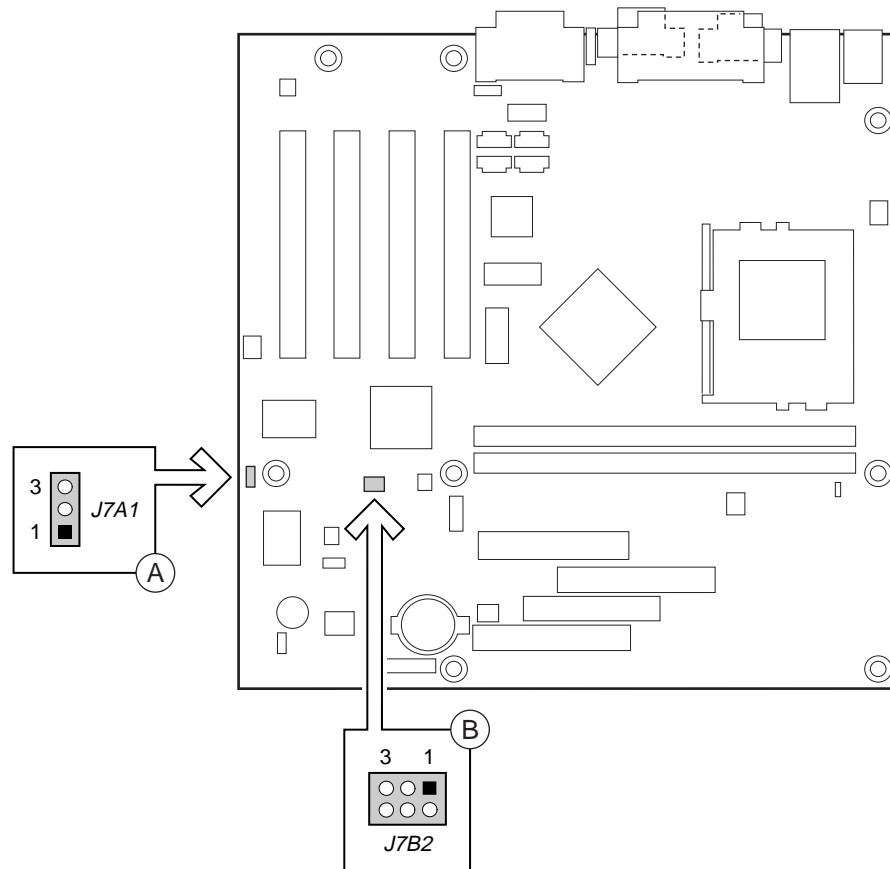

OM07760



- A BIOS Setup configuration jumper block
- B USB port configuration jumper block (optional)

Figure 14. Location of the Jumper Blocks

BIOS Setup Configuration Jumper Block

This three-pin jumper block, shown in Figure 14, enables all motherboard configuration to be done in BIOS Setup. Table 4 shows the jumper settings for the Setup program modes.

Table 4. Jumper Settings for BIOS Setup Program Modes

Function / Mode	Jumper Setting	Configuration
Normal	1-2 	The BIOS uses current configuration information and passwords for booting.
Configure	2-3 	After the Power-On Self-Test (POST) runs, the BIOS displays the Maintenance Menu. Use this menu to clear passwords and to change optional memory settings.
Recovery	none 	The BIOS attempts to recover the BIOS configuration. A recovery diskette is required.

USB Port 0 Configuration Jumper Block (Optional)

This 6-pin jumper block, shown in Figure 14, enables configuration of USB Port 0. Table 5 describes the jumper settings for configuring USB Port 0.

Table 5. USB Port 0 Configuration Jumper Settings

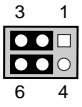
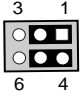
Jumper Setting	Configuration
2-3 and 5-6 	USB Port 0 signals are routed to the back panel
1-2 and 4-5 	USB Port 0 signals are routed for a front panel USB connector

3 Using the Setup Program

You can use the BIOS Setup program to change the configuration information and boot sequence for the computer. This chapter tells you how to:

- Access the BIOS Setup program
- Upgrade the BIOS
- Recover the BIOS
- Change the BIOS language
- Clear passwords

For more information about the BIOS Setup program's menus, options, and defaults settings, see the CA810 Motherboard Technical Product Specification available on the World Wide Web site:

<http://support.intel.com/support/motherboards/desktop>

⇒ NOTE

For reference purposes, you should write down the current Setup settings. When you make changes to the settings, update this record.

BIOS Setup Program Modes

The BIOS Setup program has three modes of operation:

- Normal mode for normal operations
- Configure mode for clearing passwords (See Chapter 2 for instructions)
- Recovery mode for recovering the BIOS data

The BIOS Setup program operating mode is controlled by the setting of the configuration jumper block. The jumper is set to normal mode at the factory.

⇒ NOTE

The Setup menus described in this section apply to CA810 motherboards with BIOS identifier 8C1A100A.86A. Motherboards with other BIOS identifiers might have differences in some of the Setup menu screens.

Table 6 is an overview of the menu screens in the BIOS Setup program.

Table 6. Setup Menu Screens

Setup Menu Screen	Description
Maintenance	Clears the Setup passwords. This menu is only available in configure mode.
Main	Displays system information.
Advanced	Specifies advanced features available through the chipset.
Security	Specifies passwords and security features.
Power	Specifies power management features.
Boot	Specifies boot options and power state controls.
Exit	Saves or discards changes to the BIOS Setup program options.

Function Keys

Table 7 shows the function keys available for menu screens.

Table 7. Setup Function Keys

Setup Key	Description
<Esc>	Exits the menu.
<←> or <→>	Selects a different menu screen.
<↑> or <↓>	Moves cursor up or down.
<F9>	Load the default configuration values for the current menu.
<F10>	Save the current values and exit Setup.
<Enter>	Executes command or selects the submenu.

Accessing the Setup Program

To enter the Setup program, turn the computer on and immediately press <F2> until you see the message:

Entering SETUP

Upgrading the BIOS

Before you upgrade the BIOS, prepare by:

- Obtaining the BIOS upgrade file
- Recording the current BIOS settings
- Creating a bootable diskette
- Creating the BIOS upgrade diskette

Obtaining the BIOS Upgrade File

You can upgrade to a new version of the BIOS by using the BIOS upgrade file. The BIOS upgrade file is a compressed self-extracting archive that contains all the files you need to upgrade the BIOS. The BIOS upgrade file contains:

- New BIOS files
- BIOS recovery files
- Intel® Flash Memory Update Utility

You can obtain the BIOS upgrade file through your computer supplier or from the Intel World Wide Web site:

<http://support.intel.com/support/motherboards/desktop/>

⇒ NOTE

Please review the instructions distributed with the update utility before attempting a BIOS upgrade.

The Intel Flash Memory Update Utility allows you to:

- Upgrade the BIOS in flash memory.
- Update the language section of the BIOS.

Recording the Current BIOS Settings

1. Boot the computer and press <F2> when you see the message:

Press <F2> Key if you want to run SETUP

NOTE

Do not skip step 2. You will need these settings to configure your computer at the end of the upgrade procedure.

2. Write down the current settings in the BIOS Setup program.

Creating a Bootable Diskette

⇒ NOTE

If your drive A is an LS-120 diskette drive, you must use a 1.44-MB diskette as the bootable BIOS upgrade diskette. The computer is unable to recover a BIOS from an LS-120 diskette.

To create a bootable diskette using a DOS system:

- Place an unformatted diskette in the diskette drive and format the diskette using the /s option.
Example: format a: /s
- Alternatively, place a formatted diskette in the diskette drive and use the sys command.
Example: sys a:

To create a bootable diskette using a non-DOS system:

1. Obtain the BIOS upgrade file through your computer supplier or from the Intel World Wide Web site:
http://support.intel.com/support/motherboards/desktop/
2. Copy the BIOS upgrade file to a temporary directory on your hard disk.
3. Change to the temporary directory.
4. To extract the files, double click on the BIOS upgrade file, for example, CABIOSxx.EXE.
5. One of the extracted files is MK_BOOTZ.EXE. Double click on this file to extract the README.TXT file.
6. Follow the directions in the README.TXT file.

Creating the BIOS Upgrade Diskette

1. Obtain the BIOS upgrade file through your computer supplier or from the Intel World Wide Web site:
http://support.intel.com/support/motherboards/desktop/
2. Copy the BIOS upgrade file to a temporary directory on your hard disk.
3. From the C:\ prompt, change to the temporary directory.
4. To extract the file, type the name of the BIOS upgrade file, for example, CABIOSxx.EXE
5. Press <Enter>. The extracted file contains the following files:
LICENSE.TXT
BIOINSTR.TXT
BIOS.EXE
MK_BOOTZ.EXE
6. Read the LICENSE.TXT file, which contains the software license agreement, and the BIOINSTR.TXT file, which contains the instructions for the BIOS upgrade.
7. Insert the bootable diskette into drive A.
8. To extract the BIOS.EXE file to the diskette, change to the temporary directory that holds the BIOS.EXE file and type:
BIOS A:
9. Press <Enter>.
10. The diskette now holds the new BIOS files, the Intel Flash Update Utility, and the recovery files.

Upgrading the BIOS



CAUTION

Not updating the system boot block when updating the BIOS may result in an untested system configuration. Some BIOS upgrade releases may require updating the system boot block. To find out if you need to update the boot block, go to the Intel website at:

<http://www.developer.intel.com/design/motherbd>

1. Boot the computer with the BIOS upgrade diskette in drive A. Press <Enter> to go to the Main menu. The flash memory update utility screen appears.
2. Select Update flash memory area from a file. Press <Enter>.
3. Select Update System BIOS. Press <Enter>.
4. Use the arrow keys to select the correct .bio file. Press <Enter>.
5. When the utility asks for confirmation that you want to flash the new BIOS into memory, select Continue with programming. Press <Enter>.
6. When the utility displays the message Reboot Warning, remove the diskette. Press <Enter>.
7. As the computer boots, check the BIOS identifier (version number) to make sure the upgrade was successful. If a logo appears, press <Esc> to view the POST messages.
8. To enter the BIOS Setup program, press <F2> when you see the message:

```
Press <F2> to Run SETUP
```
9. For proper operation, load the BIOS Setup program defaults. To load the defaults, press <F9>.
10. To accept the defaults, press <Enter>.
11. In Setup, enter the settings you wrote down before beginning the BIOS upgrade.
12. To save the settings, press <F10>.
13. To accept the settings, press <Enter>.
14. Turn off the computer and reboot.

Recovering the BIOS

It is unlikely that anything will interrupt the BIOS upgrade; however, if an interruption occurs, the BIOS could be damaged. The following steps explain how to recover the BIOS if an upgrade fails. The following procedure uses recovery mode for the Setup program. See Chapter 3 for more information on Setup modes.



NOTE

Because of the small amount of code available in the boot block area, there is no video support. You will not see anything on the screen during this procedure. Monitor the procedure by listening to the speaker and looking at the diskette drive LED.

1. Turn off the computer, disconnect the computer's power cord, and disconnect all external peripherals.
2. Remove the computer cover and locate the configuration jumper block (J7A1) (see Figure 1).

3. Remove the jumper from all pins as shown below to set recovery mode for Setup.



4. Insert the bootable BIOS upgrade diskette into diskette drive A.
5. Replace the computer cover, connect the power cord, turn on the computer, and allow it to boot. The recovery process will take a few minutes.
6. Listen to the speaker.
 - Two beeps and the end of activity in drive A indicate successful BIOS recovery.
 - A series of continuous beeps indicates failed BIOS recovery.
7. If recovery fails, return to step 1 and repeat the recovery process.
8. If recovery is successful, turn off the computer, and disconnect its power cord.
9. Remove the computer cover and continue with the following steps.
10. On the jumper block (J7A1), reinstall the jumper back on pins 1-2 as shown below to set normal mode for Setup.



11. Leave the upgrade diskette in drive A, replace the computer cover, and connect the computer's power cord.
12. Turn on the computer and continue with the BIOS upgrade (see page 39).

Changing the BIOS Language

You can use the BIOS upgrade utility to change the language the BIOS uses for messages and the Setup program. Use a bootable diskette containing the Intel Flash Memory Update Utility and language files (see “Upgrading the BIOS” on page 39).

1. Boot the computer with the bootable diskette in drive A. The BIOS upgrade utility screen appears.
2. Select `Update Flash Memory From a File`.
3. Select `Update Language Set`. Press `<Enter>`.
4. Select drive A and use the arrow keys to select the correct `.lng` file. Press `<Enter>`.
5. When the utility asks for confirmation that you want to flash the new language into memory, select `Continue with Programming`. Press `<Enter>`.
6. When the utility displays the message `upgrade is complete`, remove the diskette. Press `<Enter>`.
7. The computer will reboot and the changes will take effect.

4 Technical Reference

Motherboard Connectors

The motherboard's connectors can be divided into three groups, as shown in Figure 15.

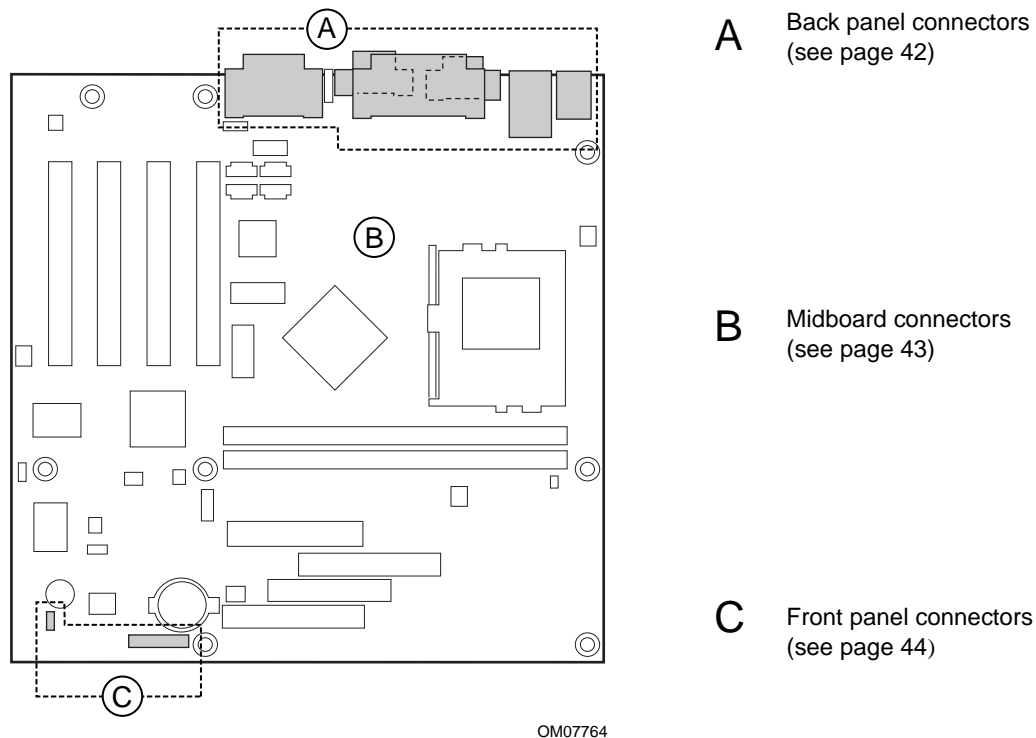

Figure 15. Connector Groups



CAUTION

Many of the midboard and front panel connectors provide operating voltage (+5 V DC and +12 V DC, for example) to devices inside the computer chassis, such as fans and internal peripherals. These connectors are not overcurrent protected. Do not use these connectors for powering devices external to the computer chassis. A fault in the load presented by the external devices could cause damage to the computer, the interconnecting cable, and the external devices themselves.

Back Panel Connectors

Figure 16 shows the back panel connectors on the motherboard.

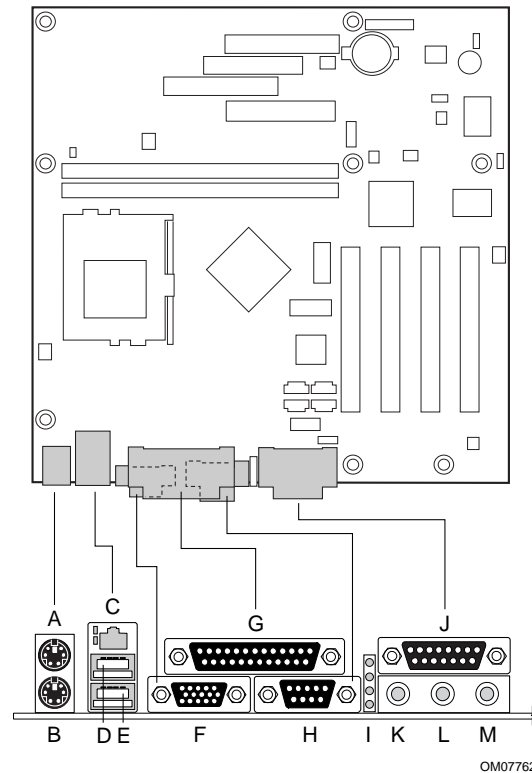

- | | | | |
|---|------------------------------------|---|-------------------------------------|
| A | PS/2 keyboard or mouse | D | USB port 0 |
| B | PS/2 keyboard or mouse | E | USB port 1 |
| C | RJ-45 LAN connector with indicator | F | VGA port |
| | LEDs (optional): | G | Parallel port |
| | - Speed | H | Serial port A |
| | Top: Green | I | Enhanced Diagnostics LED (optional) |
| | Off: 10 Mbps | J | MIDI/Game port |
| | On: 100 Mbps | K | Audio line out |
| | - Link | L | Audio line in |
| | Bottom: Yellow | M | Mic in |
| | On: Link | | |
| | Blink: Packets transferred | | |

Figure 16. Back Panel Connectors and Indicators

⇒ NOTE

The line out connector, located on the back panel, is designed to power either headphones or amplified speakers only. Poor audio quality may occur if passive (non-amplified) speakers are connected to this output.

Midboard Connectors

Figure 17 shows the location of the midboard connectors.

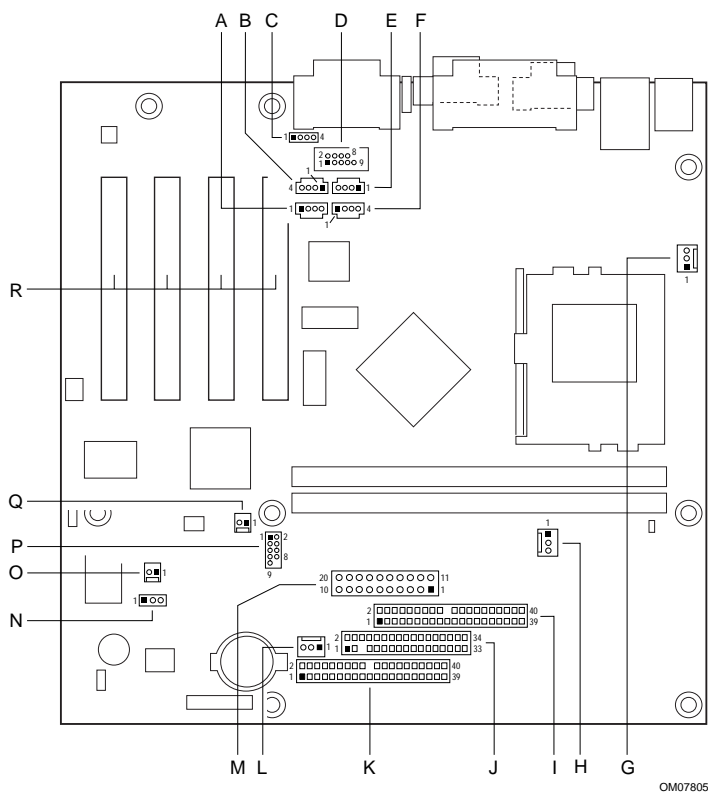

A	ATAPI-style CD-ROM	J	Diskette drive
B	Video source line in (optional)	K	Primary IDE
C	Legacy CD-ROM (optional)	L	Fan 1 (chassis)
D	Serial port B header	M	Power
E	Auxiliary line in (optional)	N	Wake on LAN technology (optional)
F	Telephony (optional)	O	SCSI HD Activity LED (optional)
G	Fan 3 (processor)	P	USB front panel (optional)
H	Fan 2 (optional)	Q	Chassis intrusion (optional)
I	Secondary IDE	R	PCI slots

Figure 17. Midboard Connectors

Front Panel Connectors

Figure 18 shows the location of the front panel connectors.

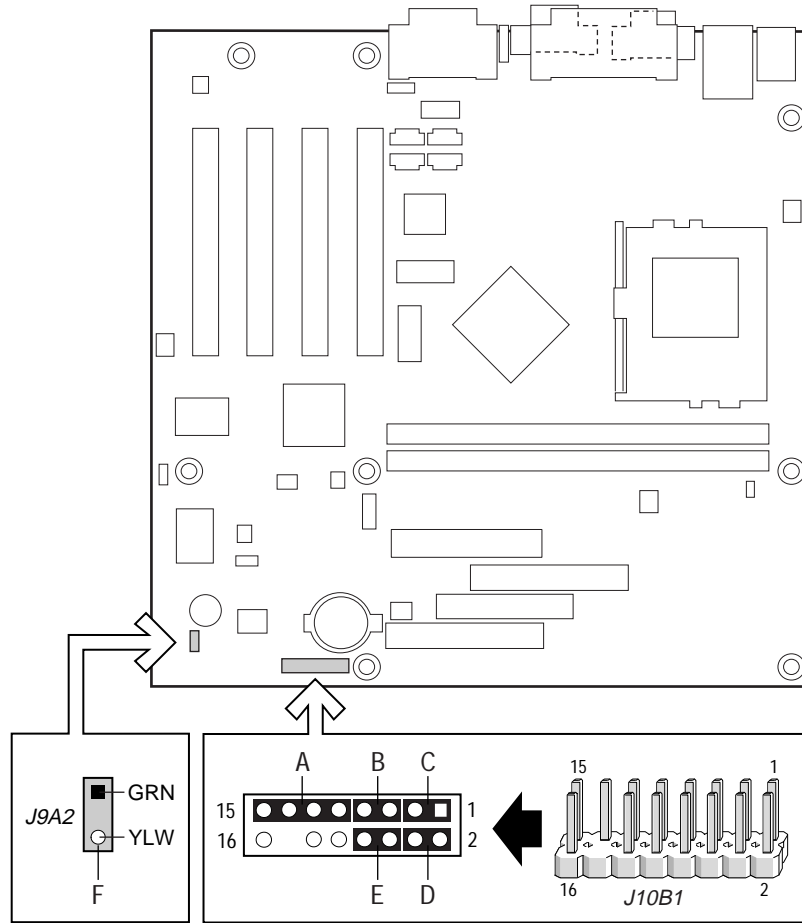

OM07767

- | | | | |
|---|-------------------------|---|-------------------------------------|
| A | Infrared port | D | Power LED |
| B | Reset switch | E | On/Off switch |
| C | Hard drive activity LED | F | Alternate 1x3 front panel power LED |

Figure 18. Front Panel Connectors

Motherboard Resources

Memory Map

Table 8. System Memory Map

Address Range (decimal)	Address Range (hex)	Size	Description
1024 K - 524288 K	100000 – 1FFFFFFF	511 MB	Extended Memory
960 K - 1024 K	F0000 - FFFFF	64 KB	Runtime BIOS
896 K - 960 K	E0000 - EFFFF	64 KB	Reserved
800 K - 896 K	C8000 - DFFFF	96 KB	Available high DOS memory (open to ISA and PCI bus)
640 K - 800 K	A0000 - C7FFF	160 KB	Video memory and BIOS
639 K - 640 K	9FC00 - 9FFFF	1 KB	Extended BIOS data (movable by memory manager software)
512 K - 639 K	80000 - 9FBFF	127 KB	Extended conventional memory
0 K - 512 K	00000 - 7FFFF	512 KB	Conventional memory

DMA Channels

Table 9. DMA Channels

DMA Channel Number	Data Width	System Resource
0	8- or 16-bits	Audio
1	8- or 16-bits	Audio / parallel port
2	8- or 16-bits	Diskette drive
3	8- or 16-bits	Parallel port (for ECP or EPP)/audio
4		DMA controller
5	16-bits	Open
6	16-bits	Open
7	16-bits	Open

I/O Map

Table 10. I/O Map

Address (hex)	Size	Description
0000 - 000F	16 bytes	DMA controller
0020 - 0021	2 bytes	Programmable Interrupt Control (PIC)
0040 - 0043	4 bytes	System timer
0060	1 byte	Keyboard controller byte—reset IRQ
0061	1 byte	System speaker
0064	1 byte	Keyboard controller, CMD/STAT byte
0070 - 0071	2 bytes	System CMOS / Real Time Clock
0072 - 0073	2 bytes	CMOS Bank 1
0080 - 0090		DMA controller
0094 - 009F		DMA controller
00A0 - 00A1	2 bytes	PIC
00B2 - 00B3	2 bytes	APM control
00C0 - 00DE	31 bytes	DMA
00F0 - 00FF		Numeric data processor
0170 - 0177	8 bytes	Secondary IDE channel
01F0 - 01F7	8 bytes	Primary IDE channel
One of these ranges: 0200 - 0207 0208 - 020F 0210 - 0217 0218 - 021F	Can vary from 1 byte to 8 bytes	Audio / game port
0220 - 022F	16 bytes	Audio (Sound Blaster Pro ⁺ -compatible)
0240 - 024F	16 bytes	Audio (Sound Blaster Pro-compatible)
0240 - 024F	16 bytes	Audio (Sound Blaster-compatible)
0278 - 027F*	8 bytes	LPT2
0228 - 022F*	8 bytes	LPT3
02E8 - 02EF*	8 bytes	COM4/video (8514A)
02F8 - 02FF*	8 bytes	COM2
One of these ranges: 0320 - 0327 0330 - 0337 0340 - 0347 0350 - 0357	8 bytes	MPU-401 (MIDI)
0376	1 byte	Secondary IDE channel command port

continued

Table 10. I/O Map (continued)

Address (hex)	Size	Description
0377, bits 6:0	7 bits	Secondary IDE channel status port
0378 - 037F	8 bytes	LPT 1
0388- 038B	6 bytes	AdLib [†] (FM synthesizer)
03B0 – 03BB	4 bytes	Intel 82810 – DC100 Graphics Controller Hub (GCH)
03C0 – 03DF	2 bytes	Graphics Controller Hub (GCH)
03CC	1 byte	Video (VGA)
03CE – 03CF	2 bytes	Video (VGA)
03D4 – 03D5	2 bytes	Video (VGA)
03DA	1 byte	Video (VGA)
03E8 – 03EF	8 bytes	COM3
03F0 - 03F5	6 bytes	Diskette channel 1
03F6	1 byte	Primary IDE channel command port
03F8 - 03FF	8 bytes	COM1
One of these ranges: 0530 – 0537 0E80 – 0E87 0F40 – 0F47	8 bytes	Windows Sound System
0800 – 087F		Motherboard resources
9000 – 9FFF		Intel 82810AA PCI bridge
LPTn + 400h	8 bytes	ECP port, LPTn base address + 400h
0CF8 - 0CFB*	4 bytes	PCI configuration address register
0CF9**	1 byte	Turbo and reset control register
0CFC - 0CFF	4 bytes	PCI configuration data register
EF00 – EF3F	64 bytes	Windows Sound System
FFA0 - FFA7	8 bytes	Primary bus master IDE registers
FFA8 - FFAF	8 bytes	Secondary bus master IDE registers
32 contiguous bytes starting on a 32-byte divisible boundary		Intel 82559 LAN controller
64 contiguous bytes starting on a 64-byte divisible boundary		Onboard audio controller

* Dword access only

** Byte access only

Interrupts

Table 11. Interrupts

IRQ	System Resource
NMI	I/O channel check
0	Reserved, interval timer
1	Reserved, keyboard buffer full
2	Reserved, cascade interrupt from slave PIC
3	COM2* (user available if COM2 is not present)
4	COM1*
5	LPT2 (Plug and Play option)/audio/user available
6	Diskette drive controller
7	LPT1*
8	Real time clock
9	User available
10	User available
11	User available
12	Onboard mouse port (if present, else user available)
13	Reserved, math coprocessor
14	Primary IDE (if present, else user available)
15	Secondary IDE (if present, else user available)

* Default, but can be changed to another IRQ.

A Error Messages

BIOS Beep Codes

Whenever a recoverable error occurs during power-on self-test (POST), the BIOS displays an error message describing the problem. The BIOS also issues a beep code (one long tone followed by two short tones) during POST if the video configuration fails (a faulty video card or no card installed) or if an external ROM module does not properly checksum to zero.

Table 12. Beep Codes

Number of Beeps	Description
1	Refresh failure
2	Parity can not be reset
3	First 64 K memory failure
4	Timer not operational
5	Processor failure (Reserved; not used)
6	8042 GateA20 cannot be toggled (memory failure or not present)
7	Exception interrupt error
8	Display memory R/W error
9	ROM checksum error (Reserved; not used)
10	CMOS Shutdown register test error
11	Invalid BIOS (such as, POST module not found)

BIOS Error Messages

Table 13. BIOS Error Messages

Error Message	Explanation
GA20 Error	An error occurred with Gate-A20 when switching to protected mode during the memory test.
Pri Master HDD Error Pri Slave HDD Error Sec Master HDD Error Sec Slave HDD Error	Could not read sector from corresponding drive.
Pri Master Drive - ATAPI Incompatible Pri Slave Drive - ATAPI Incompatible Sec Master Drive - ATAPI Incompatible Sec Slave Drive - ATAPI Incompatible	Corresponding drive is not an ATAPI device. Run Setup to make sure device is selected correctly.
A: Drive Error B: Drive Error	No response from diskette drive.

continued

Table 13. BIOS Error Messages (continued)

Error Message	Explanation
CMOS Battery Low	The battery may be losing power. Replace the battery soon.
CMOS Display Type Wrong	The display type is different than what has been stored in CMOS. Check Setup to make sure type is correct.
CMOS Checksum Bad	The CMOS checksum is incorrect. CMOS memory may have been corrupted. Run Setup to reset values.
CMOS Settings Wrong	CMOS values are not the same as the last boot. These values have either been corrupted or the battery has failed.
CMOS Date/Time Not Set	The time and/or date values stored in CMOS are invalid. Run Setup to set correct values.
DMA Error	Error during read/write test of DMA controller.
FDC Failure	Error occurred trying to access diskette drive controller.
HDC Failure	Error occurred trying to access hard disk controller.
Checking NVRAM.....	NVRAM is being checked to see if it is valid.
Update OK!	NVRAM was invalid and has been updated.
Updated Failed	NVRAM was invalid but was unable to be updated.
Keyboard Is Locked	The system keyboard lock is engaged. The system must be unlocked to continue to boot.
Keyboard Error	Error in the keyboard connection. Make sure keyboard is connected properly.
KB/Interface Error	Keyboard interface test failed.
Memory Size Decreased	Memory size has decreased since the last boot. If no memory was removed, then memory may be bad.
Memory Size Increased	Memory size has increased since the last boot. If no memory was added, there may be a problem with the system.
Memory Size Changed	Memory size has changed since the last boot. If no memory was added or removed, then memory may be bad.
No Boot Device Available	System did not find a device to boot.
Off Board Parity Error	A parity error occurred on an offboard card. This error is followed by an address.
On Board Parity Error	A parity error occurred in onboard memory. This error is followed by an address.
Parity Error	A parity error occurred in onboard memory at an unknown address.
NVRAM / CMOS / PASSWORD cleared by Jumper	NVRAM, CMOS, and passwords have been cleared. The system should be powered down and the jumper removed.
<CTRL_N> Pressed	CMOS is ignored and NVRAM is cleared. User must enter Setup.

B Regulatory and Integration Information

This appendix contains:

- Safety standards, electromagnetic compatibility regulations, and product certification markings for this motherboard
- Instructions and precautions for integrators who are installing this motherboard in a chassis

Regulatory Compliance

This motherboard complies with the following safety and EMC regulations when correctly installed in a compatible chassis

Table 14. Safety Regulations

Regulation	Title
UL 1950/CSA950, 3 rd edition, Dated 07-28-95	Bi-National Standard for Safety of Information Technology Equipment including Electrical Business Equipment. (USA and Canada)
EN 60950, 2 nd Edition, 1992 (with Amendments 1, 2, 3, and 4)	The Standard for Safety of Information Technology Equipment including Electrical Business Equipment. (European Community)
IEC 950, 2 nd edition, 1991 (with Amendments 1, 2, 3, and 4)	The Standard for Safety of Information Technology Equipment including Electrical Business Equipment. (International)
EMKO-TSE (74-SEC) 207/94	Summary of Nordic deviations to EN 60950. (Norway, Sweden, Denmark, and Finland)

Table 15. EMC Regulations

Regulation	Title
FCC Class B	Title 47 of the Code of Federal Regulations, Parts 2 and 15, Subpart B, pertaining to unintentional radiators. (USA)
CISPR 22, 2 nd Edition, 1993 (Class B)	Limits and methods of measurement of Radio Interference Characteristics of Information Technology Equipment. (International)
VCCI Class B (ITE)	Implementation Regulations for Voluntary Control of Radio Interference by Data Processing Equipment and Electronic Office Machines. (Japan)
EN55022 (1994) (Class B)	Limits and methods of measurement of Radio Interference Characteristics of Information Technology Equipment. (Europe)
EN50082-1 (1992)	Generic Immunity Standard; Currently compliance is determined via testing to IEC 801-2, -3, and -4. (Europe)
ICES-003 (1997)	Interference-Causing Equipment Standard, Digital Apparatus, Class B (Including CRC c.1374) (Canada)
AS/NZ 3548	Australian Communications Authority (ACA), Standard for Electromagnetic Compatibility

Product Certification Markings

This printed circuit assembly has the following product certification markings:

- UL Joint Recognition Mark: Consists of small c followed by a stylized backward UR and followed by a small US (Component side)
- Manufacturer's recognition mark: Consists of a unique UL recognized manufacturer's logo, along with a flammability rating (94V-0) (Solder side)
- UL File Number for motherboards: E139761 (Component side)
- PB Part Number: Intel bare circuit board part number (Solder side) 730515-004
- Battery "+ Side Up" marking: located on the component side of the board in close proximity to the battery holder
- FCC Logo/Declaration: (Solder side)
- ACA (C-Tick) mark: Consists of a unique letter C, with a tick mark; followed by N-232. Located on the component side of the motherboard and on the shipping container.
- CE Mark: (Component side) The CE mark should also be on the shipping container

Installation Precautions

When you install and test the motherboard, observe all warnings and cautions in the installation instructions.

To avoid injury, be careful of:

- Sharp pins on connectors
- Sharp pins on printed circuit assemblies
- Rough edges and sharp corners on the chassis
- Hot components (like processors, voltage regulators, and heat sinks)
- Damage to wires that could cause a short circuit

Observe all warnings and cautions that instruct you to refer computer servicing to qualified technical personnel.



WARNING

Do not open the power supply. Risk of electric shock and burns from high voltage and rapid overheating. Refer servicing of the power supply to qualified technical personnel.

Installation Instructions



CAUTION

Follow these guidelines to meet safety and regulatory requirements when installing this board assembly.

Read and adhere to all of these instructions and the instructions supplied with the chassis and associated modules. If the instructions for the chassis are inconsistent with these instructions or the instructions for associated modules, contact the supplier's technical support to find out how you can ensure that your computer meets safety and regulatory requirements. If you do not follow these instructions and the instructions provided by chassis and module suppliers, you increase safety risk and the possibility of noncompliance with regional laws and regulations.

Ensure Electromagnetic Compatibility (EMC)

Before computer integration, make sure that the power supply and other modules have passed EMC testing using a motherboard with a processor from the same family and operating at the same (or higher) speed as the processor on this motherboard.

In the installation instructions for the host chassis, power supply, and other modules pay close attention to the following:

- Certifications
- External I/O cable shielding and filtering
- Mounting, grounding, and bonding requirements
- Keying connectors when mismating of connectors could be hazardous

If the power supply and other modules have not passed applicable EMC testing before integration, EMC testing must be conducted on a representative sample of the newly completed computer.

Ensure Chassis and Accessory Module Certifications

Make sure that the chassis, any added subassembly, such as a board or drive assembly, and internal or external wiring, are certified for the region(s) where the end-product will be used. Marks on the product are proof of certification. Certification marks are as follows:

In Europe

The CE marking signifies compliance with all relevant European requirements. If the chassis does not bear the CE marking, obtain a supplier's Declaration of Conformity to the appropriate standards required by the European EMC Directive and Low Voltage Directive. Other directives, such as the Machinery and Telecommunications Directives, might also apply depending on the type of product. No regulatory assessment is necessary for low voltage DC wiring used internally or wiring used externally when provided with appropriate overcurrent protection. Appropriate protection is provided by a maximum 8-A current limiting circuit or a maximum 5-A fuse or positive temperature coefficient (PTC) resistor. All Intel motherboards now have PTCs on all external ports that provide DC power externally.

In the United States

A certification mark by a Nationally Recognized Testing Laboratory (NRTL) such as UL, CSA, or ETL signifies compliance with safety requirements. External wiring must be UL Listed and suitable for the intended use. Internal wiring must be UL Listed or Recognized and rated for applicable voltages and temperatures. The FCC mark (Class A for commercial or industrial only or Class B for residential) signifies compliance with electromagnetic interference requirements.

In Canada

A nationally recognized certification mark such as CSA or cUL signifies compliance with safety requirements. No regulatory assessment is necessary for low voltage DC wiring used internally or wiring used externally when provided with appropriate overcurrent protection. Appropriate protection is provided by a maximum 8-A current limiting circuit or a maximum 5-A fuse or positive temperature coefficient (PTC) resistor. All Intel motherboards now have PTCs on all external ports that provide DC power externally.

Prevent Power Supply Overload

Unless the power supply has inherent overcurrent protection, do not overload the power supply output. To avoid overloading the power supply, make sure that the calculated total current load of all the modules within the computer is less than the output current rating of the power supply. If you do not do this, the power supply could overheat, catch fire, or damage the insulation that separates hazardous AC line circuitry from low-voltage user accessible circuitry. If the load drawn by a module cannot be determined by the markings and instructions supplied with the module, contact the module supplier's technical support.

Place Battery Marking on the Computer

There is insufficient space on this motherboard to provide instructions for replacing and disposing of the battery. The following warning must be placed permanently and legibly on the chassis as near as possible to the battery.



WARNINGS

Danger of explosion if battery is incorrectly replaced.

Replace with only the same or equivalent type recommended by the manufacturer. Dispose of used batteries according to the manufacturer's instructions.

Use Only for Intended Applications

This motherboard was evaluated for use in computers that will be installed in offices, homes, schools, computer rooms, and similar locations. The suitability of this product for other applications, (such as medical, industrial, alarm systems, and test equipment) might require further evaluation.